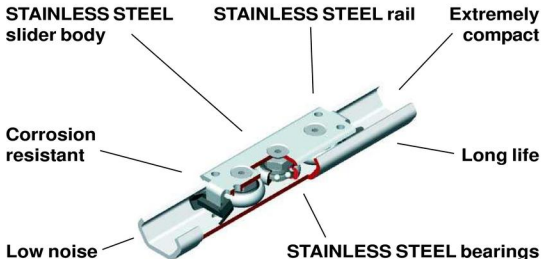

INDEX

TEX - CEX SERIES.....	F4
MOUNTED RAIL/SLIDER.....	F5
RAIL (TEX - TES).....	F5
SLIDER (CEX - CES).....	F6
ROLLERS.....	F7
LOAD CAPACITIES.....	F8
TECHNICAL DATA.....	F8
APPLICATION FIELDS.....	F8

TEX - CEX SERIES*...perfect for washdowns!*

X RAIL is a family of *inexpensive stainless steel* or *zinc-plated steel* linear bearings. This family is a simple and cost-effective linear bearing for applications where good load capacity and corrosion resistance are most important and where high precision machine-tool, profiled-shaft linear bearings are an unnecessary and expensive solution. Instead of paying for the overkill, specify the right solution. The following are some of the many advantages that the product offers:

- Corrosion resistant even after scratching, etching, and chipping
- Can be used in washdowns
- Resistant to high temperatures and temperature changes
- No coatings that could flake or chip
- Low coefficient of friction
- Ecological and recyclable materials

One version of the formed rail (**TEX**) is made of AISI316L stainless steel. It comes in lengths up to 3 meters (9'10"). The raceways are internal for better protection and compactness.

The sliders (**CEX**) have three stainless steel (AISI440) radial ball bearings with double rubber seals (2RS) and are lubricated for life. These rollers have eccentric pivots that allow adjusting the preload when mounted inside the rail. The rollers are mounted to the stainless steel (AISI316L) slider body. A solution proven for years in our hardened Compact Rail, sliders moving inside internal raceways guarantees the best level of protection against impurities, debris, and external abuse. The sliders come standard with hard wipers that scrape any eventual debris off of the races.

When a cost effective solution is needed but stainless steel is not, we offer a formed, zinc-plated steel (BS1449-HR1) solution. The plated solution (**TES-CES**) offers higher load capacities of its stainless brother and is offered in the same dimensions as well.

It represents a very cost effective solution for all those applications where good loading performance and simple mounting are considered key features and where ground, high-performance square and round shafting is simply overkill and over budget.

MOUNTED RAIL / SLIDER

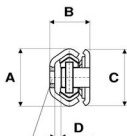
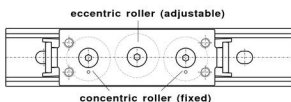

Size	A	B	C	D	Fixing Screws *
TEX20 - CEX20	19.2	16	18	2.5	M4
TEX30 - CEX30	29.5	20.5	27	3.5	M5
TEX45 - CEX45	46.4	31	40	5	M8

* Fixing Screws:

- Hexagon socket oval head screws ISO 7380 stainless steel / zinc plating (not supplied)
- Torx® screw (supplied upon request)

Notes:

- use the same values for zinc plated version (TES.. - CES..)

- to set rail/slider preload, see instructions on page A26 (COMPACT RAIL family)

RAIL (TEX - TES)

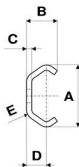
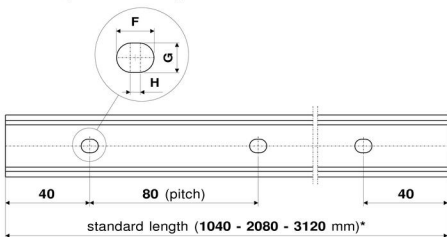

* Special lengths are available upon special order. Please consult your nearest branch or distributor for more information

Size	A	B	C	D	E	F	G	H	Fixing Screws	Weight [g/m]
TEX20 - TES20	19.2	10	2	7	3	7	5	2	M4	470
TEX30 - TES30	29.5	15	2.5	10	4.5	8.4	6.4	2	M5	900
TEX45 - TES45	46.4	24	4	15.5	6.5	11	9	2	M8	2290

Order Code:

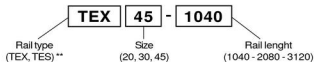

** TEX = stainless steel rail; TES = zinc plated rail

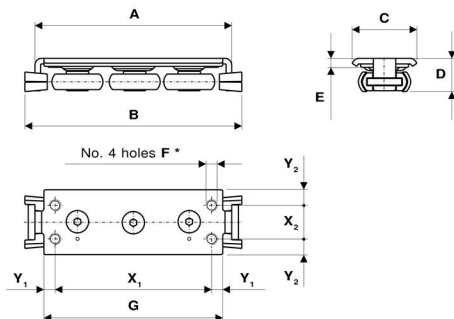
SLIDER (CEX - CES)

* only for CEX20 / CES20: No. 2 holes (F)

Size	A	B	C	D	E	F	G	X1	Y1	X2	Y2	Weight [g]
CEX20 - CES20	80	90	18	11.5	5.5	M5	71	60	10	/	9	55
CEX30 - CES30	88	97	27	15	4.5	M5	80	70	5	15	6	120
CEX45 - CES45	150	160	40	22	4	M6	135	120	7.5	23	8.5	390

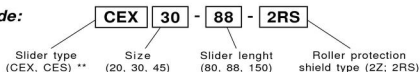
Order Code:

** CEX = stainless steel slider; CES = zinc plated slider

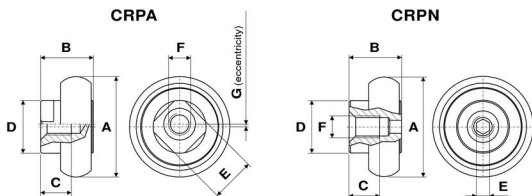
ROLLERS

Type	A	B	C	D	E	F	G	Weight [g]
CRPN20-2Z CRPNX20-2RS	14	8.5	6	9	3	M4	/	5
CRPA20-2Z CRPAX20-2RS	14	8.5	6	9	8	M4	0.5	5
CRPN30-2Z CRPNX30-2RS	22.8	12	7	12	3	M5	/	18
CRPA30-2Z CRPAX30-2RS	22.8	12	7	12	10	M5	0.6	18
CRPN45-2Z CRPNX45-2RS	35.6	18	12	17	3	M6	/	60
CRPA45-2Z CRPAX45-2RS	35.6	18	12	17	15	M6	0.8	60

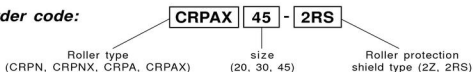
Order code:

LOAD CAPACITIES

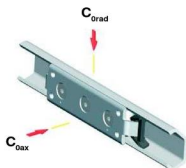

Type	C_{0rad} [N]	C_{0ax} [N]
TEX20 - CEX20	300	170
TEX30 - CEX30	800	400
TEX45 - CEX45	1600	860

Type	C_{0rad} [N]	C_{0ax} [N]
TES20 - CES20	326	185
TES30 - CES30	870	435
TES45 - CES45	1740	935

TECHNICAL DATA

- **Max. temperature:** 120° C (266°F) for CES sliders, 100° C (212°F) for CEX sliders
- **Speed:** 1,5 m/s (59 in/s)
- **Corrosion resistance:** Minerals oils, water, methanol, solvents

APPLICATION FIELDS

- **Food industry:** production and packing of food / beverages
- **Chemical and Environment industry:** water treatment devices
- **Medical industry:** analysis equipment
- **Transport industry:** sliding doors and boat constructions
- **Power industry:** boilers and house fireplaces
- **Mechanical devices:** car wash and automatic gates
- **Machine tools:** protective panel movement